

# Installation Instructions

# SWING GATES & PEDESTRIAN GATES



**CE** NF EN 13241+A2  
compliant

**UK  
CA** compliant

- A** *Installation Instructions*
- B** *Equipment*
- C** *A little vocabulary*
- D** *Information / Opening tolerance*
- E** *Preparing the gate*
- F** *Fixing the bottom pivot*
- G** *Fixing the top hinge*
- H** *Fixing the centre stop*
- I** *Adjusting the top hinge*
- J** *Adjusting the bottom pivot and adjustable stop*
- L** *Fixing the floor fixed gate stop*
- M** *Fitting the electric strike*
- N** *Electric strike catcher post*
- O** *Resin fixed hinges*
- P** *Narrow type hinges*
- Q** *Rising hinges*
- *Optional aluminium posts*
- *End of installation*

horiz **AL**

# A

## Installation instructions

The gate must be installed in accordance with the installation instructions provided by HORIZAL in this installation guide. Only a professional installer is authorized to install this gate, as well as to undertake maintenance, repair and dismantling operations. In the case of a motorization not supplied by HORIZAL, the installer must ensure that the motor chosen complies with the characteristics of the installed gate and that its installation complies with:

- for CE marking: the NF EN 13241+A2 standards and following directives: the Machinery Directive 2006/42/EC (Low Voltage Directive 2014/35/EU, EMC Directive 2014/30/EU, Radio Equipment Directive 2014/53/EU)
- for UKCA marking: the UKCA standards and following regulations: Supply of Machinery (Safety) Regulations 2008 (Electrical Equipment (Safety) Regulations 2016, EMC Regulations 2016, Radio Equipment Regulations 2017)

The installer will add a second compliance label next to the HORIZAL label according to the model presented here.

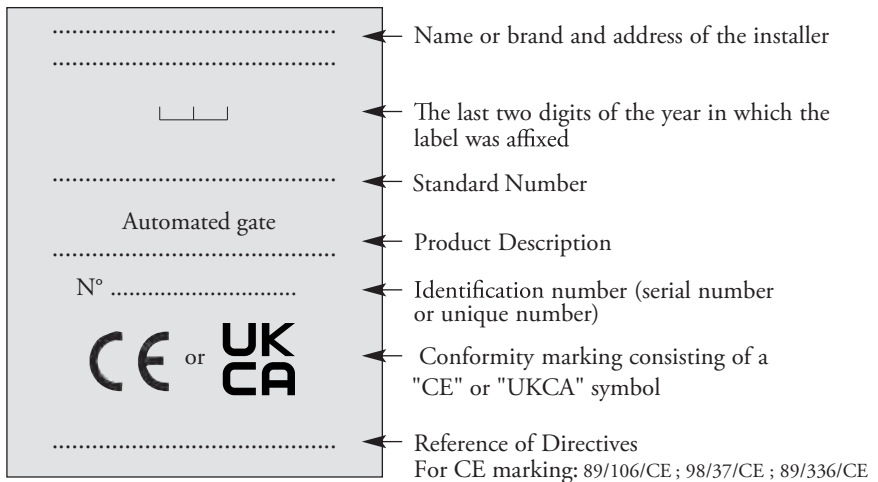

# B

## Equipment

### Tools required to install the gates:

- 17 mm spanner
- 17 mm socket and ratchet
- 17 mm ring spanner
- Allen keys 2.5 - 10 mm
- Stanley knife
- Tape measure
- Level / plumb line
- Clamp
- Drill
- Phillips screwdriver
- 2 Shims 55 mm
- 2 Shims 12 mm



Fixings are not supplied.  
Recommended fixings suitable  
for brickwork:

- 4 x M10 threaded bar and chemical anchor recommended
- 4 x M10 throughbolt concrete fixings for the ground pivots
- 4 x M8 throughbolt concrete fixings for the centre stop



# The gate parts

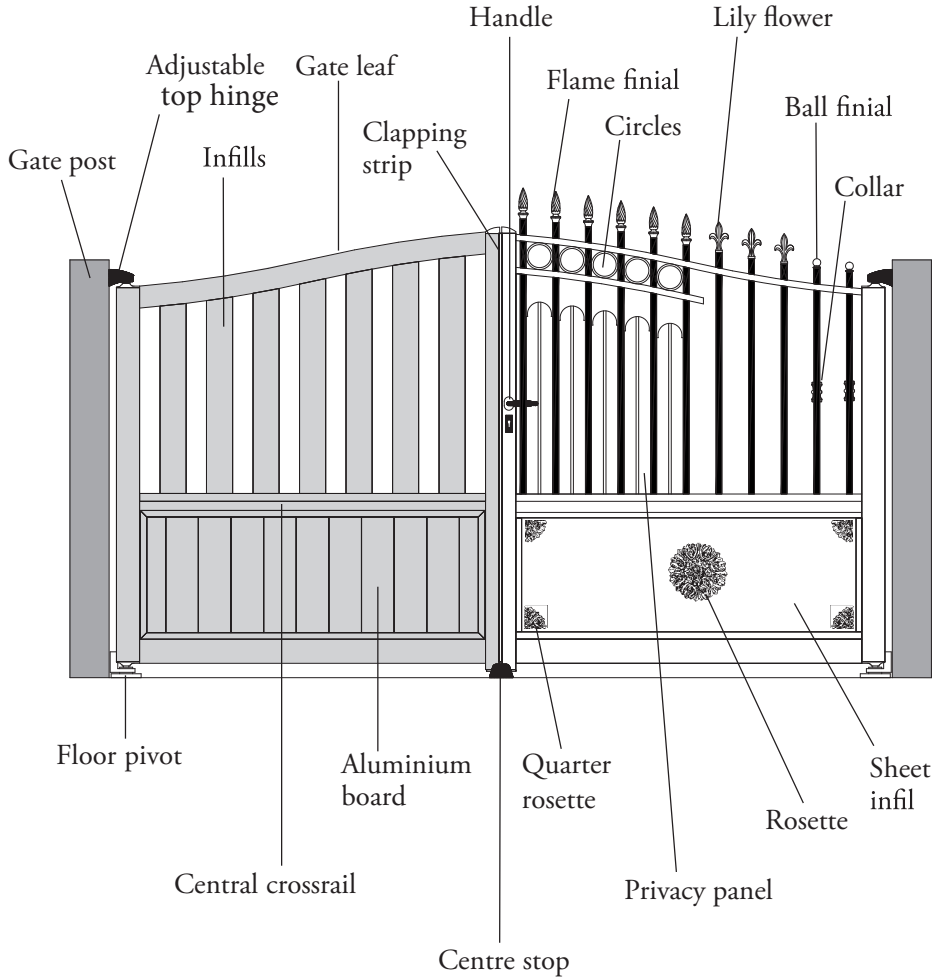

# D *Information / Opening Tolerance*

- 1 The gate posts must be straight and aligned and if fixing to brickwork reinforced concrete or supporting steel column inside the pillar
- 2 Height of the pillars should be 100mm above the top of the gate shoulder
- 3 The threshold must be flat and level.
- 4 The opening area of the gate must be horizontal or downhill.

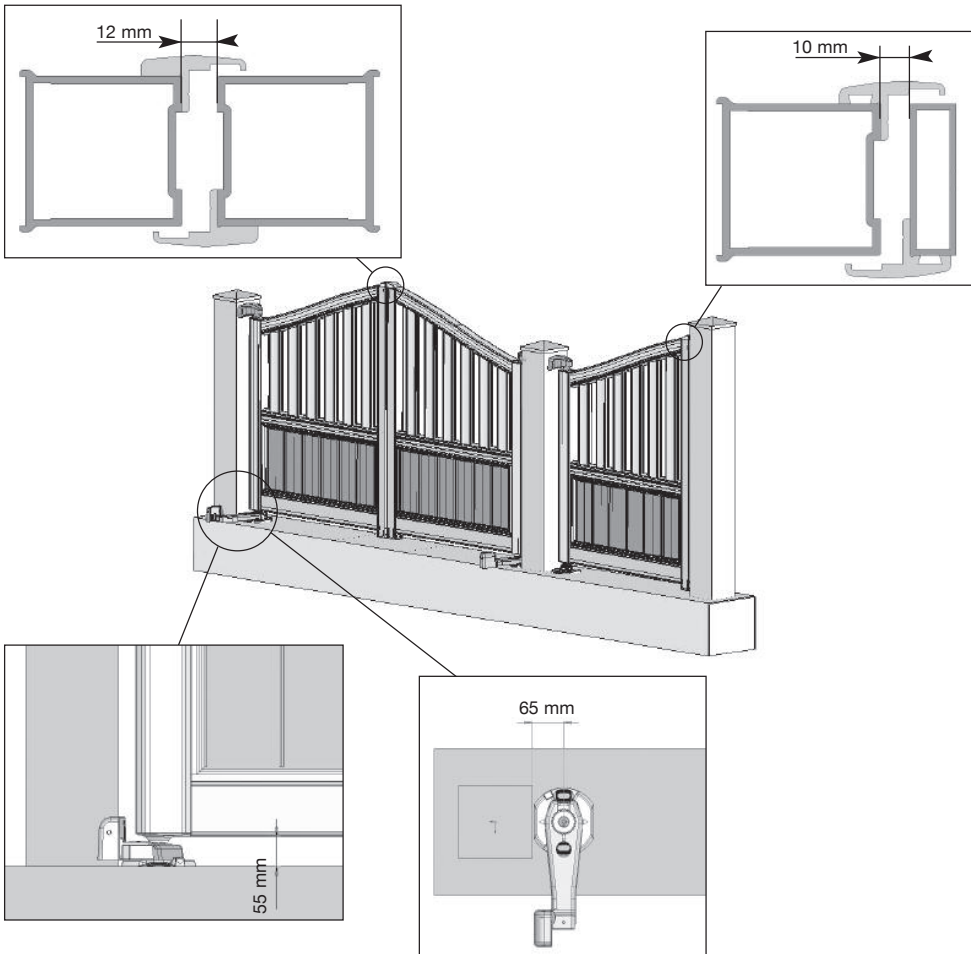

# E *Preparing the gates*

## ① Assembly of the handle (TRADITION range gates)

Insert the square shaft into the lock.  
Fix the handles on the leaf with the 2 screws ① & ② and fit the cover ③.  
Lock the handles on the square section axle using the special 3 mm hexagon screw - key supplied ④.



## ② Adjusting the bolt's direction



Remove the black cover.  
Screw or unscrew using a 4 mm Allen key.  
To turn the bolt : loosen the screw completely (4 mm Allen key).  
Turn the bolt, turn the screw, put the cover back on.

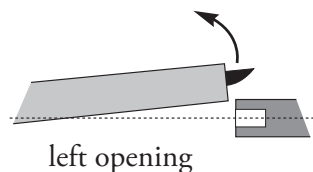
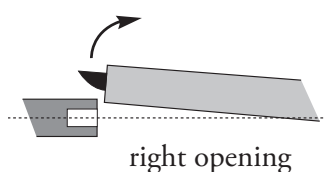
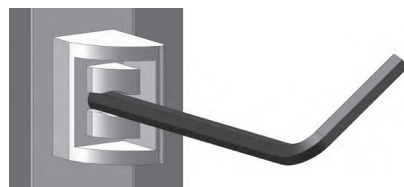

## ③ Assembly of the handle of the CONTEMPORARY gates



Insert the square shaft into the lock and check the direction of the handle when mounting. This handle is fixed by 4 screws on each side. Rotate the covers by pushing them with your thumb to reveal the mounting holes. Same settings as for the "Tradition

# STANDARD INSTALLATION

## **F** *Fixing the bottom pivot*

- 1 Position the pivot centre 65 mm from the pillar the two fixing holes being located on either side of the vertical plane of the gate.

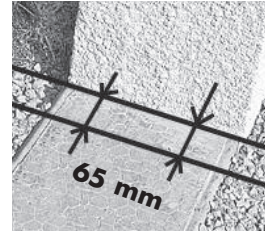

- 2 Drill the fixing holes at a slight angle
- 3 Fix the M10 throughbolts (with serrated washers).

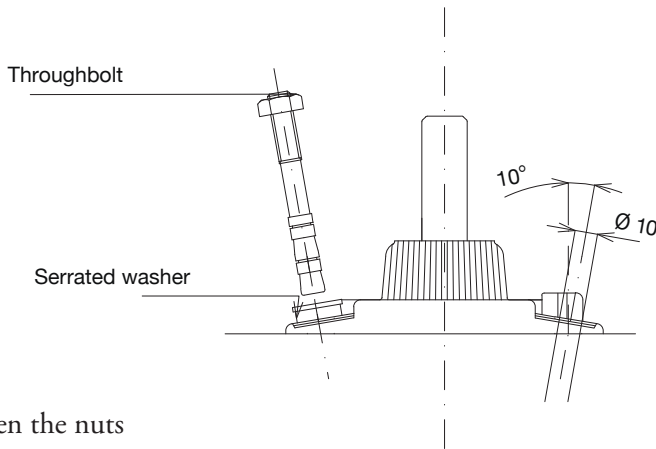

- 4 Tighten the nuts
- 5 Mount the integrated stop, without tightening the screws.



*Stops are handed  
left & right*

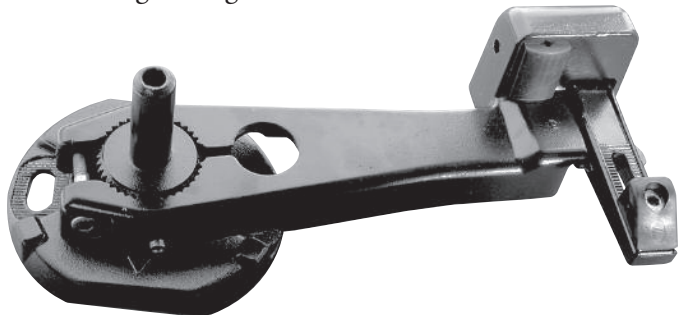

# G

## *Fixing the top pivot*

- 1 Position the gate on the pivot with the aid of a 55mm shim to keep it level. Remove the cover and fit the hinge in the top collar of the leaf allowing a vertical clearance of 3 mm (to allow expansion).

*Proceed in the same way for both leaves.*

- 2 Check the leaf is vertical and mark the centre of the 2 holes in the circular openings.



- 3 Remove the leaf.
- 4 Drill the 2 holes of a  $\varnothing$  suited to your fixings.
- 5 Reposition the gate leaf.
- 6 Place the hinge back in the top hole of the gates and fix to the pillars using suitable fixings and the large washer supplied.

# H *Fitting the centre stop*

- 1 Close the gate, making sure that the two leaves are correctly aligned, and place the stop in the centre so that each leaf touches a rubber buffer.
- 2 Open a leaf, mark the location of the stop and the mounting holes for the 2 screws.
- 3 Drill to the same diameter as the used anchor bolt. Blow the dust away. Put on the anchor bolts.
- 4 Put the stop into position. Insert the screws into the two holes and tighten.

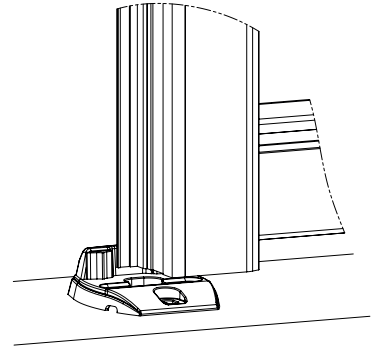

## Information about the universal centre stop

There are 2 possible mounting positions.

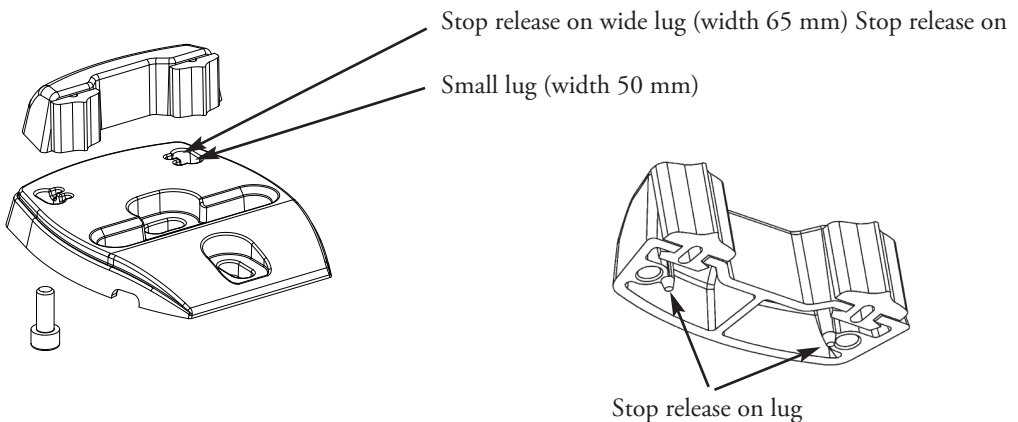



# I Hinge Adjustment

- 1 Ensure the gate is vertical.  
Rotate the washer to the desired position.  
Tighten the fixing screws.

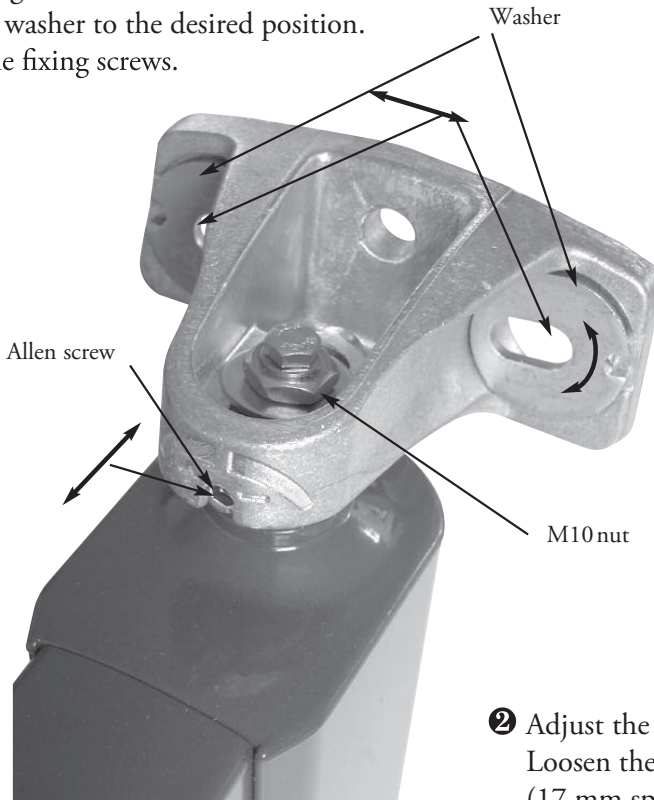

- 2 Adjust the gate until level.  
Loosen the nut M10  
(17 mm spanner).  
Use the adjusting screw  
(5 mm spanner).  
Tighten the M10 nut.

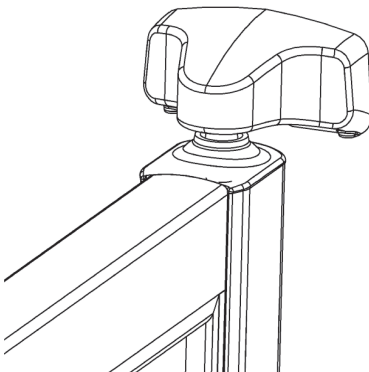

- 3 Fit the hinge cover.

## **J** *Adjusting the floor pivot and gate stop*

- 1 If necessary, adjust the floor pivot. For easier access to the screws, lift the integrated stop and fold it against the closed leaf.
- 2 Swing the leaf into the open position and locate the gate stop on the splines.
- 3 Tighten the clamp bolt.
- 4 Tighten the anti-lift screw.

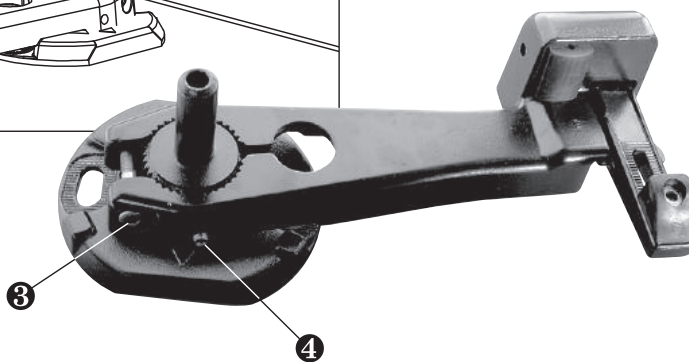
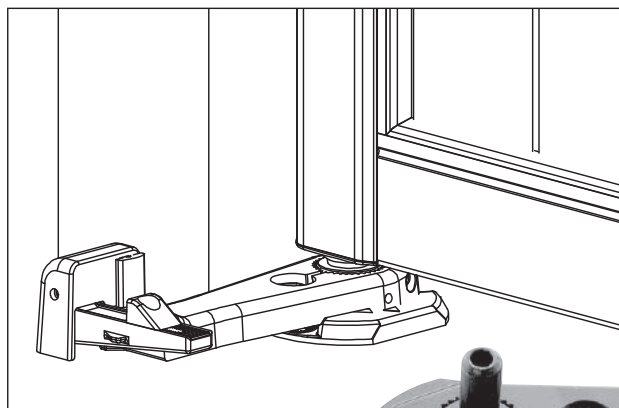

## **K** *Bolt Adjustment*

10 See page 5

## OTHER CONFIGURATIONS

# L

### *Fixing the concrete in opening stop*

- 1 Set up the opening stop at a distance of 1.25 m minimum from the pivot.
- 2 Prepare a hole for concrete about 15 x 15 x 15 cm.
- 3 Move the opening stop to a height of 5 mm below the gate.
- 4 Fix the stop in the concrete.

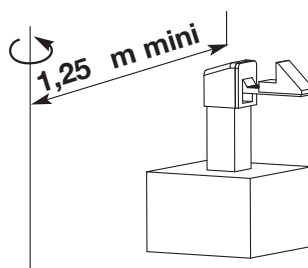
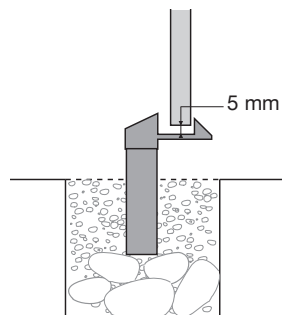

# M

### *Electric strike for swing gates*

The electric strike is factory fitted in the leaf. The gate is equipped with pivots (for the mounting procedure of the thrust bearing see page 6). The electric strike can be operated by a button, a digital code or a key switch. It acts as a lock. The bolt is released by the lock through application of 12 volts AC or DC.

To junction box  
or code lock.

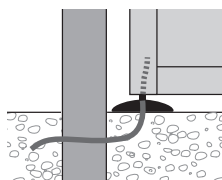

Cable inside  
the gate leaf.

1.5 meters of electrical  
wires out at the location  
of the floor pivot.



*The floor pivots have a cable route to allow the cable to pass through.*



# N

## Electric strike for pedestrian gates

To install the electric strike profile, start by making a cut out in the pillar at the location of the strike. Allow a few extra millimeters for the lock. Then put the profile in place on the ground against the pillar. Close the gate. Adjust the profile. Open the gate, while holding the profile against the pillar. Mark the location of the screws.

Drill the fixing holes. Position the profile. Thread and pull the electrical wires into the feed tube (which must be hidden by the profile) to the outlet or junction box. Tighten the screws.

- Anchor bolts: 3 female bolts M8
- Screws supplied: 3 countersunk screws M8 x 45

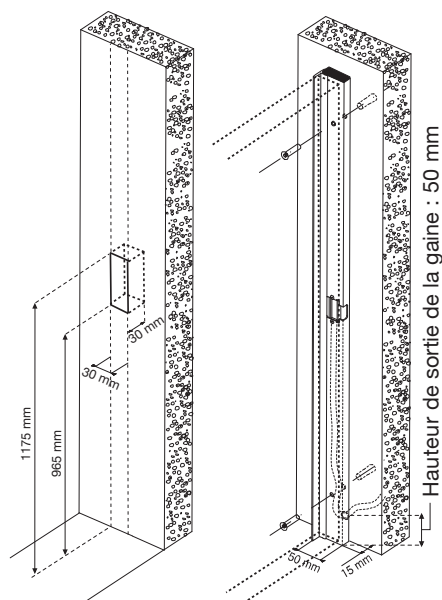

### Turning the lock into an electric strike lock

- Make sure the lock is unlocked.
- Remove the cover.
- Insert a 4mm Allen key.
- Three-quarter turn the key anti-clockwise.

#### CHECKING

- Lock the lock.  
You have to be able to pull back the latch fully. The handle should be locked but the latch should now be sprung so it can fit into the electric strike lock.
- Put the cover back





# Resin fixed pivot

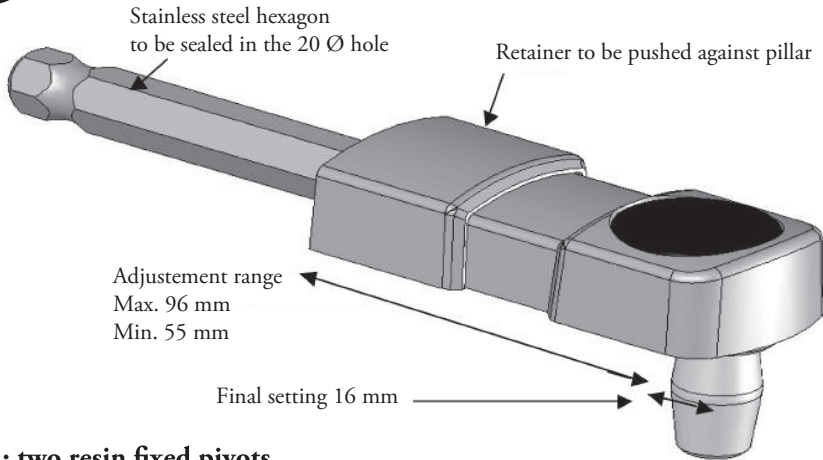

## Case 1: two resin fixed pivots

### 1 Bottom pivot:

30 mm from the ground, drill a  $\text{Ø} 20$  hole with a depth of 120 mm. Use a chemical seal to fasten the pivot.

### 2 Top pivot:

Put the gate in place. Drill a  $\text{Ø} 20$  hole with a depth of 120 mm (3 mm clearance) 30 mm from the top of the pivot mount.

Before fitting the fixed pivot, remove its bolt and put it in the pivot mount, with both flat sides in the fixed pivot's setting pin. Insert the chemical seal. Put on the pivot. Tighten the pin again in the middle of the adjustment range, making sure the sides are properly slotted into the groove.

After the seal has been applied, finalise the leaves' positioning. Push the retainers against the pillar and use the bottom screw to keep them in place.

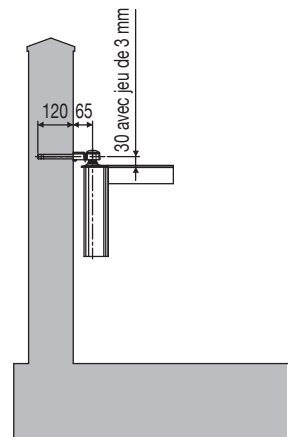
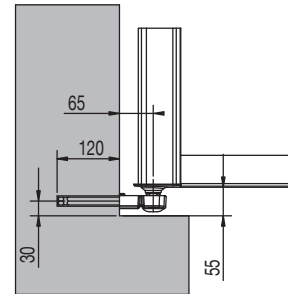

## Case 2: a resin fixed pivot + floor pivot

1 See page 6 for details of how to fit the floor pivot.

2 See above for details of how to fit the top pivot.

# P Hinges

## Case 1: Hinges fixed between pillars

- 1 Put the gate in place and drill hinge holes in the middle.
- 2 Fit the bolts and tighten the fastenings. Anchor bolts: max. 25 mm protruding.

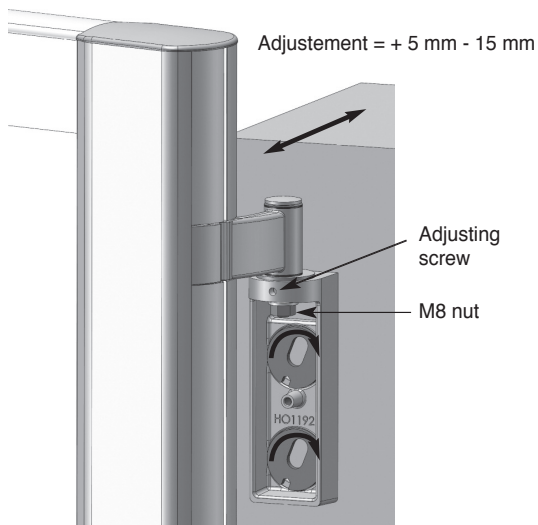

*Bolts: 8 male bolts M10*

- 3 Adjust the gate horizontally:
  - Loosen the M8 nut
  - Use the 3mm Allen key to tighten or loosen the adjusting screw

**Note: always ensure the gate is not bearing its weight when you are tightening or loosening the adjusting screw. Once adjustment has been completed, tighten the M8 nut.**
- 4 Vertical adjustment can be performed by changing the direction of the washers.
- 5 Tighten the cover (3mm Allen key).



## Case 2: Hinges fixed at the rear of the pillars

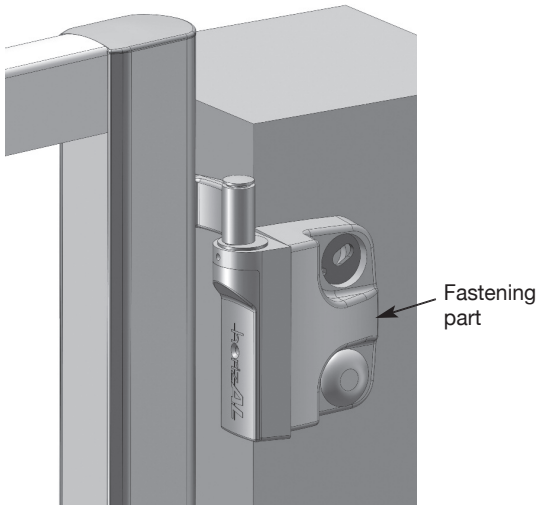

- 1 Put the gate in place.
- 2 Position the fastening parts.
- 3 Fit the bolts.  
Bolt: max. 25mm protruding.
- 4 Tighten the fastening parts.
- 5 Adjust as appropriate  
(see hinges fixed between pillars).
- 6 Fit the covers.

*Bolts: 8 male bolts M10*

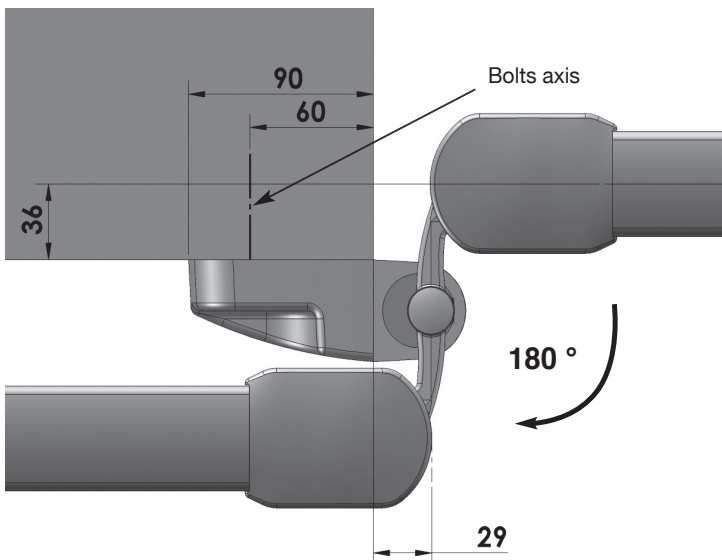

# Q

## Rising hinge

### ① Fitting the rising hinge part

- Fit the leaf into a fixed position with a ground clearance of 55 mm.
- Put the rising hinge ① in position
- Mark the outline of the part.
- Remove the gate.
- Reposition the part in the outline.
- Mark the fastening holes.
- Drill.
- Fit the anchor bolts.
- Attach the part.

OPEN  
GATE

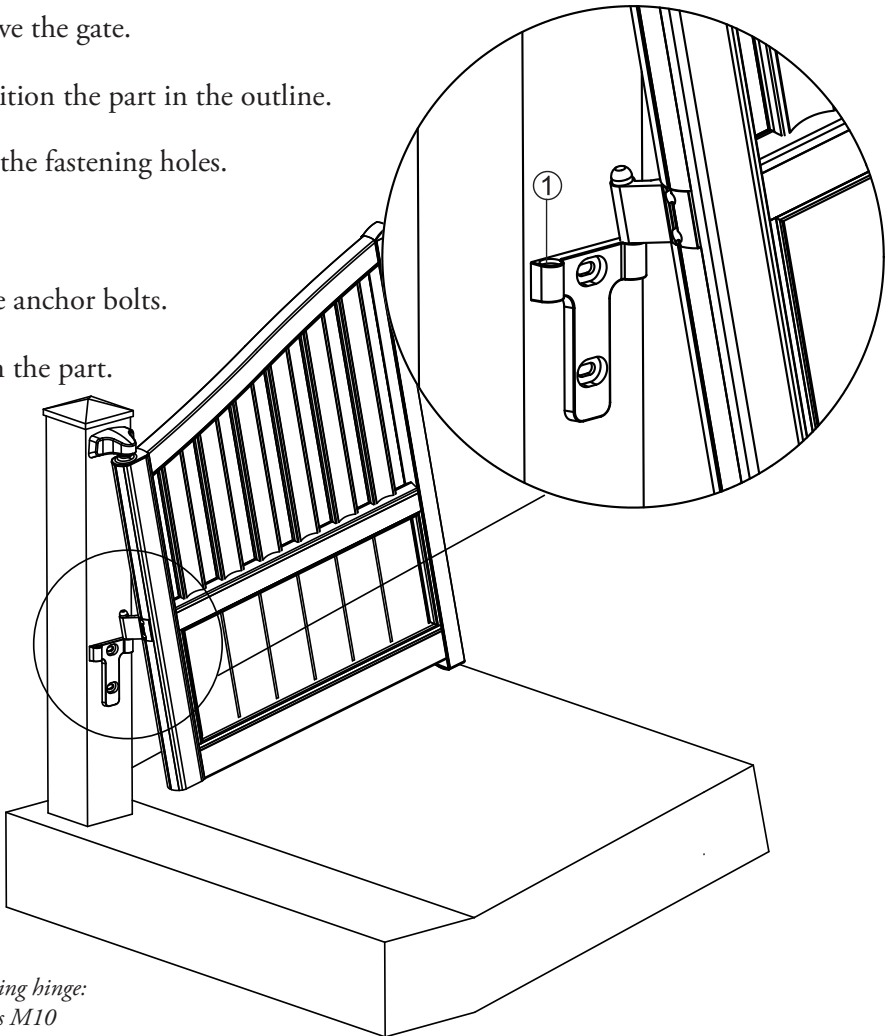

*Bolts for rising hinge:  
4 male bolts M10*



## ② Fitting the top pivot (see page 7)

- Reposition the leaf.
- Engage the top pivot.
- Leave 2 mm clearance between the ring and the axis.
- Fit the top pivot (see page 7).
- Perform tests and make any adjustments needed (see page 9).
- Fit the centre top (see page 8).
- Fit the buffers to be sealed (see page 11).

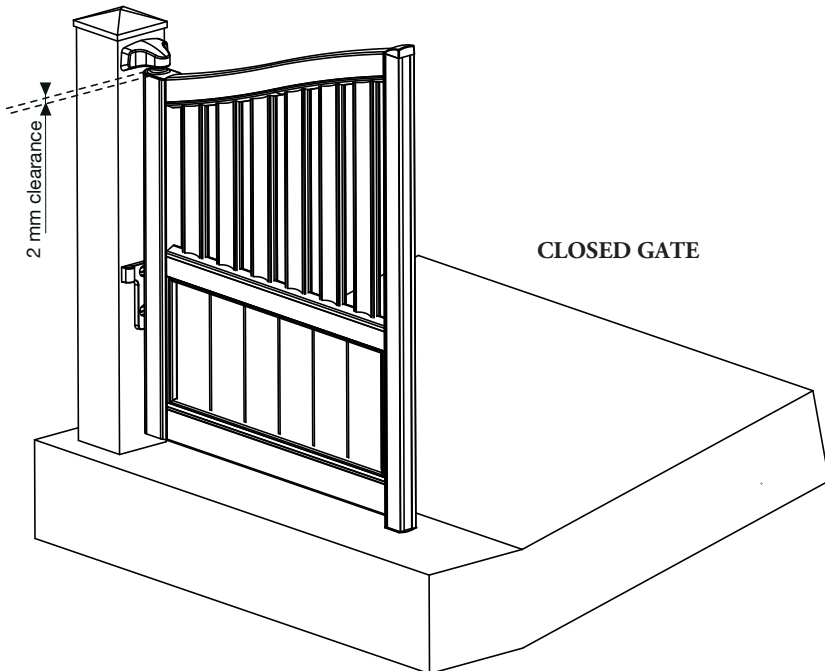

OPTION

## *Aluminium posts*

If your front gate or pedestrian gate has 150 x 150mm aluminium posts, these are adapted to their height. Below are the steps to take to make them work.

- 1 When pouring the slab, dig 2 holes of at least 200 x 200mm, with width around 1.5 times the total length of the post.

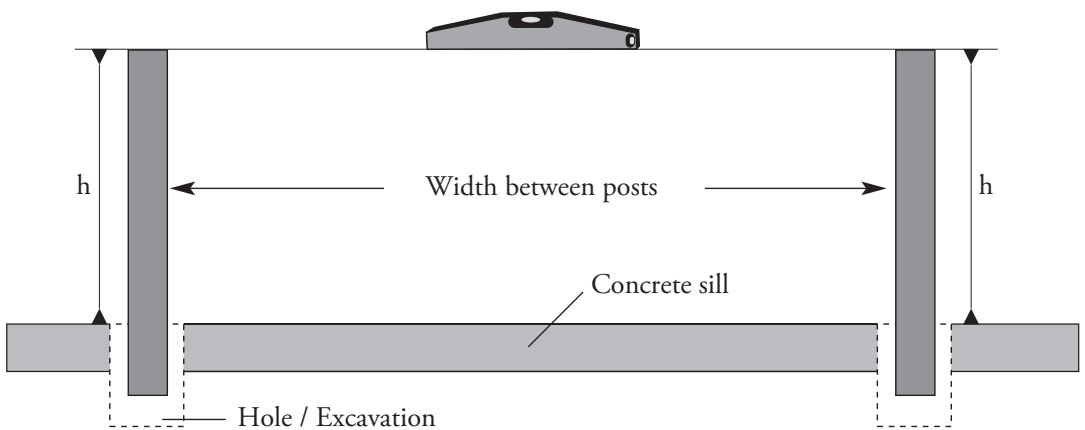

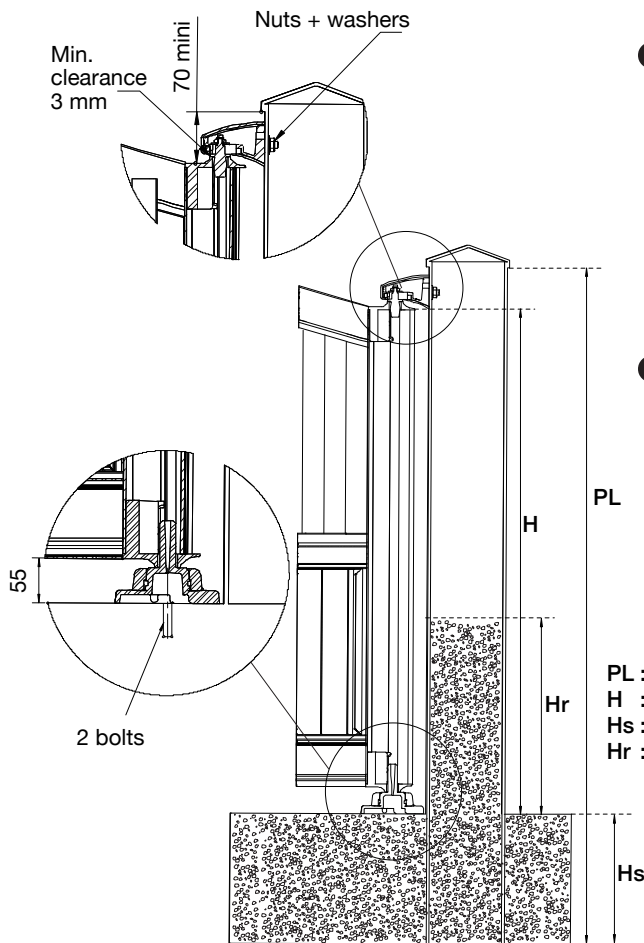

② Install the post and fix them while making sure they are vertical and checking their level. They must be at the same height. The width of the posts should be adjusted depending on the gate to be fitted

③ The concrete is poured into the space and then inside the post. It should reach to one third of the post's visible height.

PL : Total length of post  
 H : Height of gate  
 Hs : Height of seal  
 Hr : Fill height above ground  
 (1/3 of post's visible height)

④ After the concrete sets, take the same steps in the same order as for standard fitting. The floor pivot is fitted to the sill (identical to concrete post). The top pivot is fitted on to the post with 2 M10 screws and a bolt + washer inside the post.  
*Screws recommended for 1 pivot: 2 hexagonal headed screws M10 x 30.*

⑤ Fit the post caps.

# *Regulations*

## *Instructions for finishing up*

Discard all packaging material in accordance with prevailing standards. It is essential to comply with all requirements of the EN 12604 and EN 12453 standards, with compliance checked as appropriate.

## *Disassembling / Demolition*

Any disassembling should only be undertaken by a professional. Disassembling should be carried out by following the reverse of the assembly process.

Precautions must be taken to hold the gate in place so that it cannot fall. Materials must be disposed of in accordance with prevailing standards.

## *Alterations and enhancements*

Any alteration or enhancement of the gate is only authorised if the gate continues to meet all the requirements of NF EN 13241+A2 and UKCA standards.

IMPORTER: Alucorb Ltd

Unit 5 Milton Industrial Court  
Horsfield Way, Bredbury Park Industrial Estate  
Bredbury, Stockport, SK6 2TD

horiz **AL**

March 2023