

Installation instructions

SLIDING GATE



UK
CA



NF EN 13241+A2
compliant

- A** *Installation Instructions*
- B** *Equipment*
- C** *Definitions*
- D** *Pre start site inspection*
- E** *Fitting the handle*
- F** *Fitting the wheels and covers*
- G** *Gate catcher installation*
- H** *Fitting the ground track*
- I** *Fitting the top roller guide
(flat top gates)*
- J** *Fitting the support posts
(curved top gates)*
- K** *Fitting the back stop*
- L** *Final fixing of the gate catcher*
- M** *Adjusting the gate lock (manual gate)*
- N** *Fixing the gate catcher cover
(manual gate)*
- N₁** *Fixing the gate catcher cover
(automated gate)*
- O** *Fitting the catcher post buffer*
- *Optional aluminium posts*
- *Optional automation*
- *Final checks*

A Installation Instructions

The gate must be installed in accordance with installation instructions provided by HORIZONTAL in this guide. Only a professional installer is entitled to fit this gate, and to undertake maintenance work or repair and disassembly. In the case of automation not provided by Horizontal, the installer must ensure that the motor (EC) is suited to the gate size and that the installation complies with the NF EN 13241+A2 and UKCA standards.

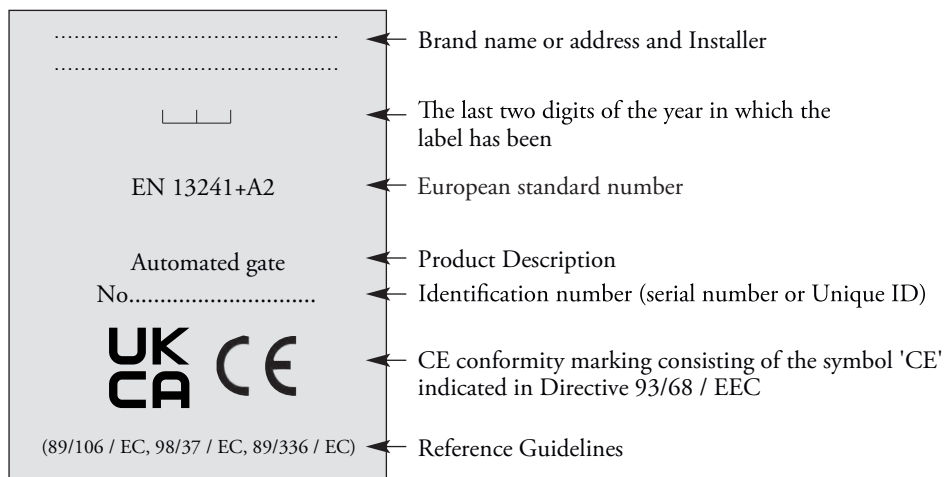

B Equipment

Your tools for successful installation of your portal:

- Hammer drill
- Concrete drill Bits
- Spanners 13mm and 19mm
- 17mm Flat spanner
- Flexible tube (blow gun) 50 cm
- Spirit level
- Tape measure
- Hexagon key 2.5, 3, 4 and 5mm
- Phillips screwdriver
- Hammer
- Carpenter's pencil
- 2 rafters or 2 trestles
- 1 block (1 cm thickness, width 4 cm)
- 2 wedges (5 cm wide)
- Masons ruler



The anchors used for fixing must be suitable for the foundations

- M8 Anchors (*not provided by Horizontal*)
 - Screws for fixing the ground track (about 2 plugs per metre)
- M12 Anchors (support posts)



A little vocabulary...

FLAT TOP GATES

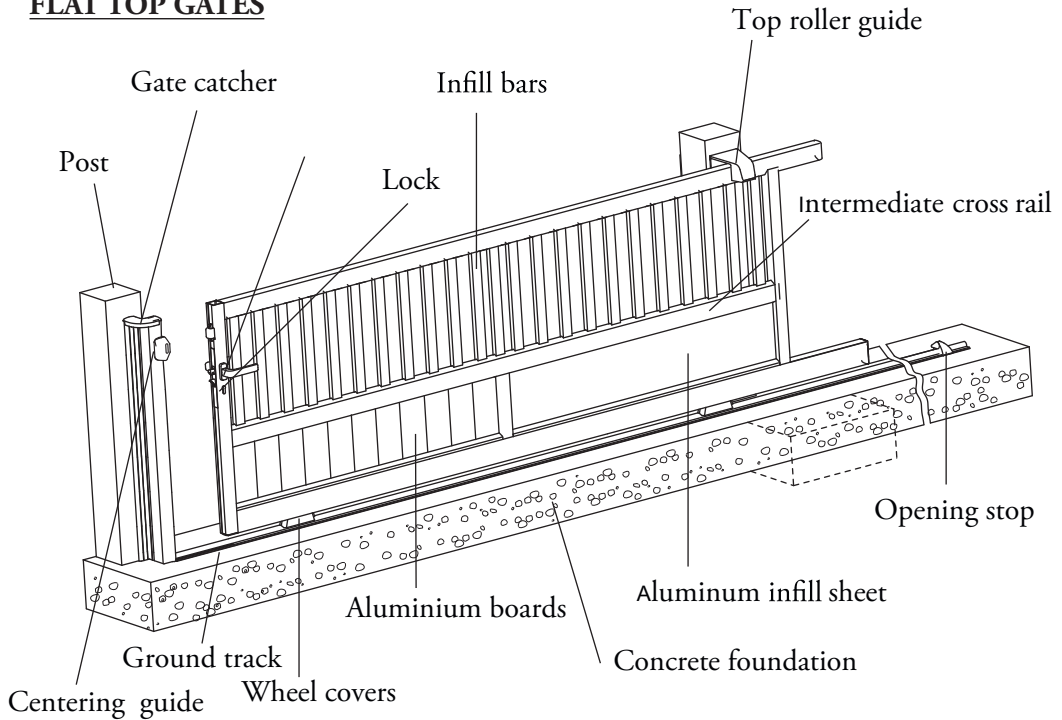

CURVED TOP GATES

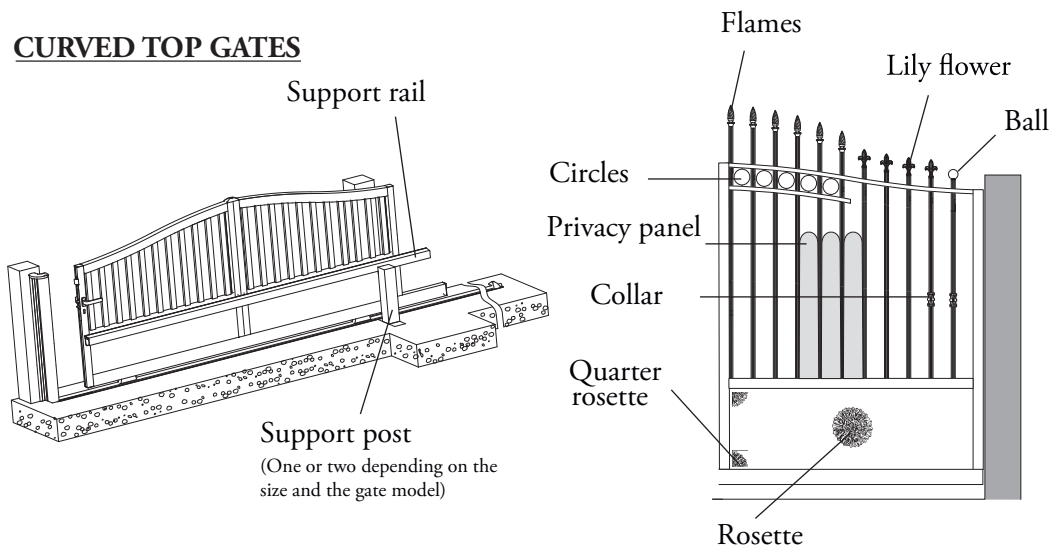

D Installation start checks

- Check the width of the gate.
- Check the height of the posts.
- Check the level of the concrete foundation and the opening dimension.
The ground track will be bolted to the foundation.

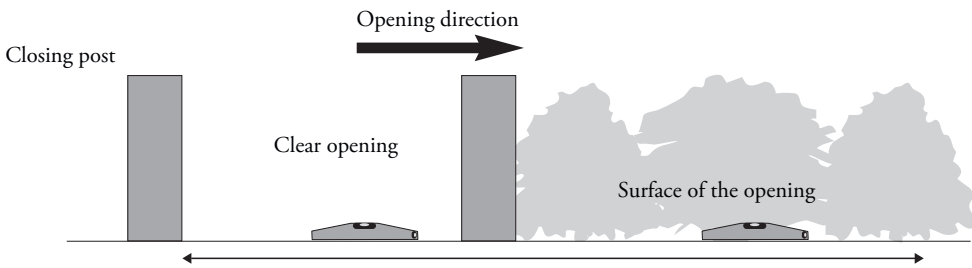
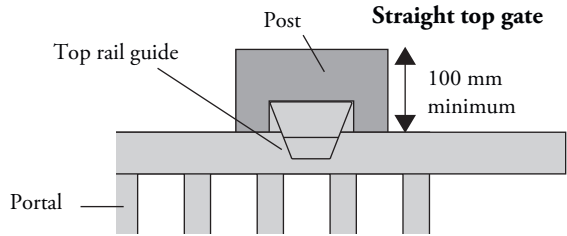

- The concrete foundation must have a depth of about 500 mm and a minimum width of 170 mm minimum.

With top support guide Flat top model

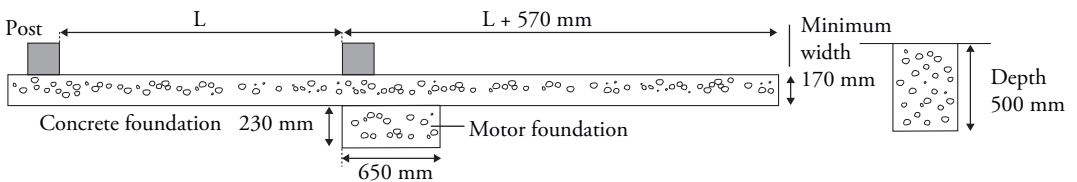

With 1 support post Curved top gates less than 4000mm

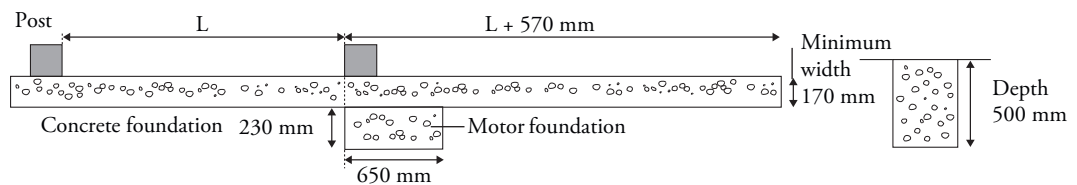

With 2 support posts Curved top gate greater than 4000mm opening

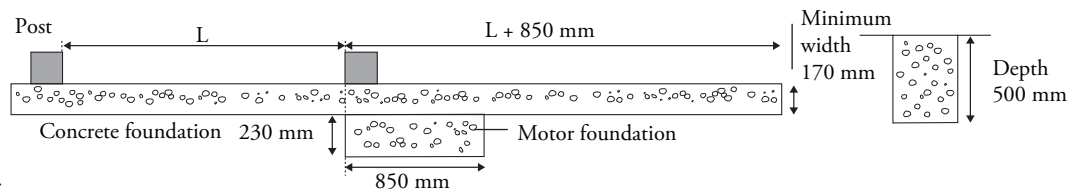

E *Fitting the handle*

Insert the square pin in the lock.

Fix the handles using the screws provided 1 & 2 and clip on the cover 3.

Lock the handles on the square pin using the special 3 mm hexagon screw 4 (supplied)

Traditional model handles

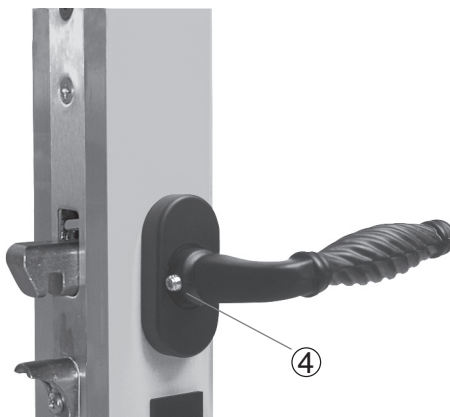

The handles of Contemporary Models are mounted the same way



F

Fitting the wheels and covers

- Lay the gate flat on trestles
Place the wheels in the slots provided under the gate and insert the wheel pins into the holes through the section.
- Place washers on each side.
- Install the screws and tighten, making sure the wheel turns freely.
- Insert the screw covers.
- Mount the wheel covers using the 2 screws.

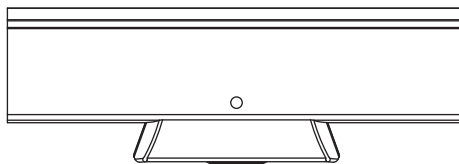
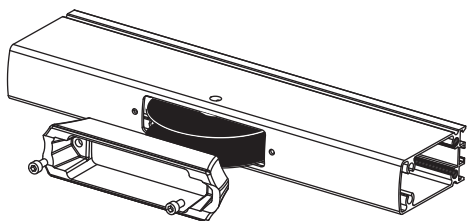
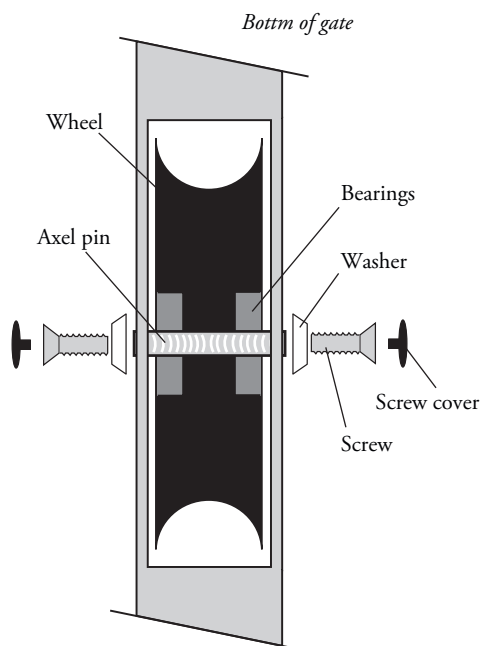

G *Partial installation of closing post*

This partial installation will define the track starting point.

- On the pillar mark a vertical line as per drawing (right).
- Position the closing post and mark the lower fixing hole.
- Drill the hole for the fixing.
- Mount the post.
- Fasten the post in place using the bottom fixing. Check the post is vertical. The fixing of the 2 other screws will be at the end of the installation.

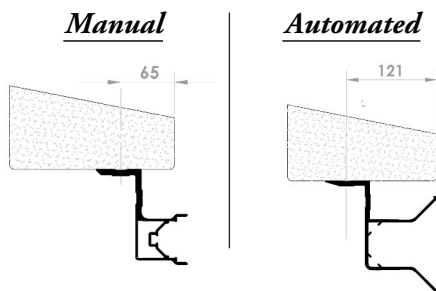
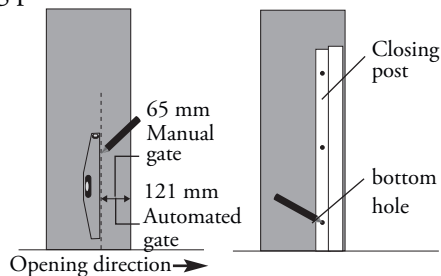

H *Ground track*

- Assemble the track lengths with the connecting sleeves and place the track on the foundations
- **Manual gate**
Place the track up to the catcher post and fasten into position using the connecting sleeves. (aluminum tube Ø 16).

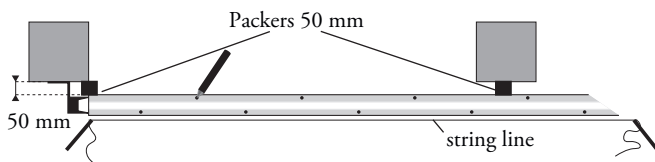

Automated gate

Place the track into the V of the catcher post

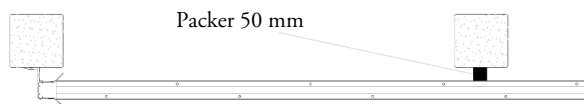

- Use a 50mm packer between the track and the pillar. Check the track is straight using a string line.
- Fix the ground track into position.



Fixing the upper guide - flat top gates

- Put the gate in place on the ground track, in the closed position with the front of the gate in the catcher post.
- Place the top roller guide in the middle of the pillar equidistant from the edges.

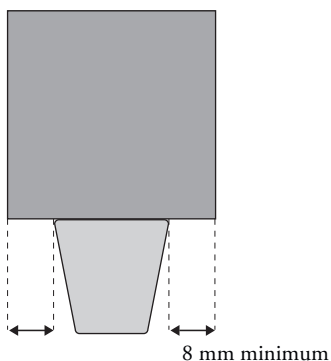

- Place the top roller guide on top of the gate with a 10mm packer and trace the outline of the guide in pencil.

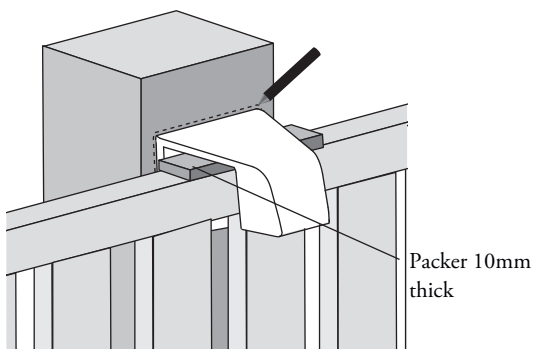

- Remove the gate from the track and place on trestles, time to fix the guide.
- Position the guide in the pencil lines and mark out the fixing holes.

- Install the top roller guide.
- Replace the gate and slide it into the top roller guide.

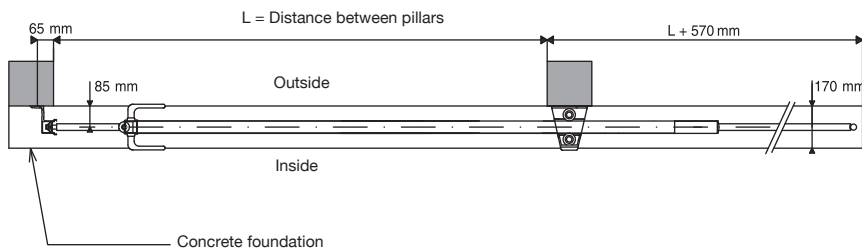
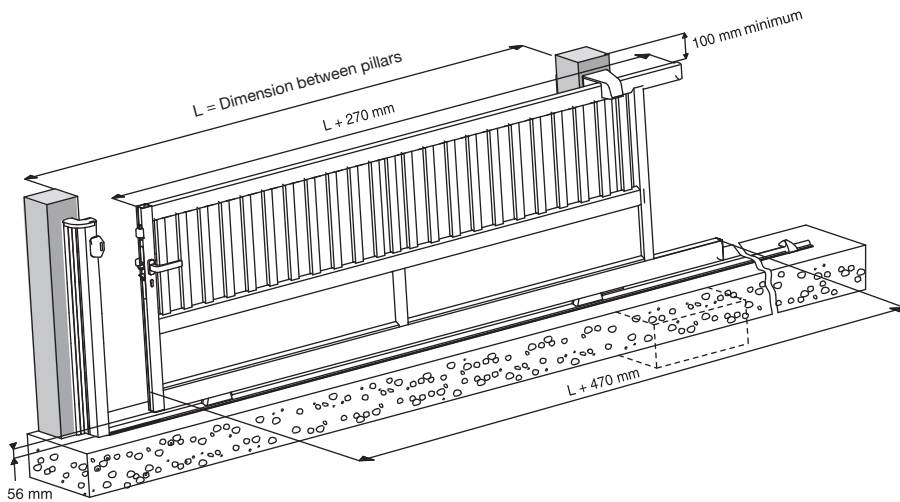

! DIMENSIONS IN MM

Installation measurement

Height reference the gate H	guide H1	pillar h
1250 mm	1236 mm	1350 mm
1500 mm	1486 mm	1600 mm
1750mm	1736 mm	1850 mm
2000mm	1986 mm	2,100 mm

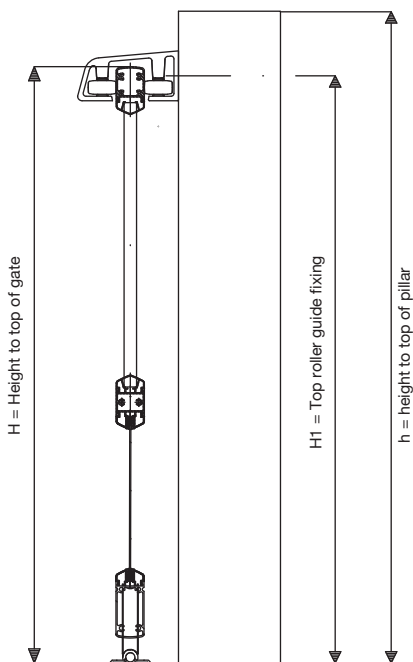

J

Side support posts for swept top gate and Traditional gates

The installation of the side guide involves a suitable concrete foundation (see page 4).

Some gates come with two post guides depending on the size and model.

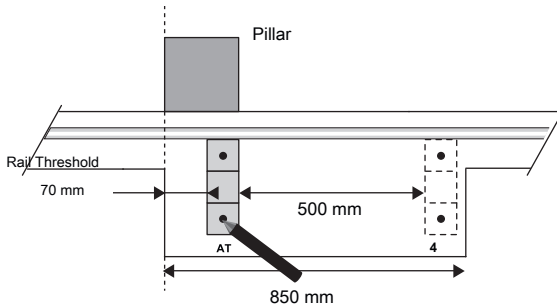

- Position the post side guide against the rail and 70 mm from the edge of the foundation.

- Mark precisely the location of the mounting holes.

- Prepare the fixings.

[If you have an additional guide post, do the same. The guide post is located at a distance of 50 cm from the first and also against the rail.]

- The fasteners are ready, put the gate up, closed, holding it vertically so that it can not fall. *See p.11 scheme.*
- Remove the end cover at the end of the support rail by loosening the screw located under the profile (Allen key 6mm). *See p.11 scheme.*
- Insert the roller in this profile and move the post to its location. *See p.11 scheme.*
- Secure the post. *See p.11 scheme.*

Do the same with the additional guide post B.

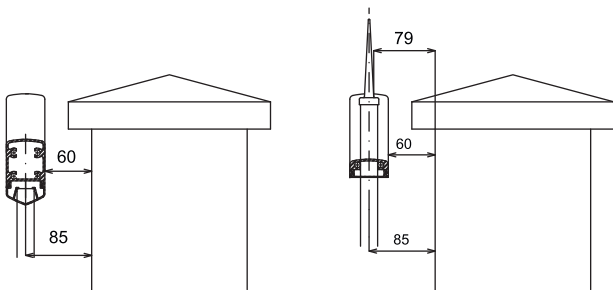
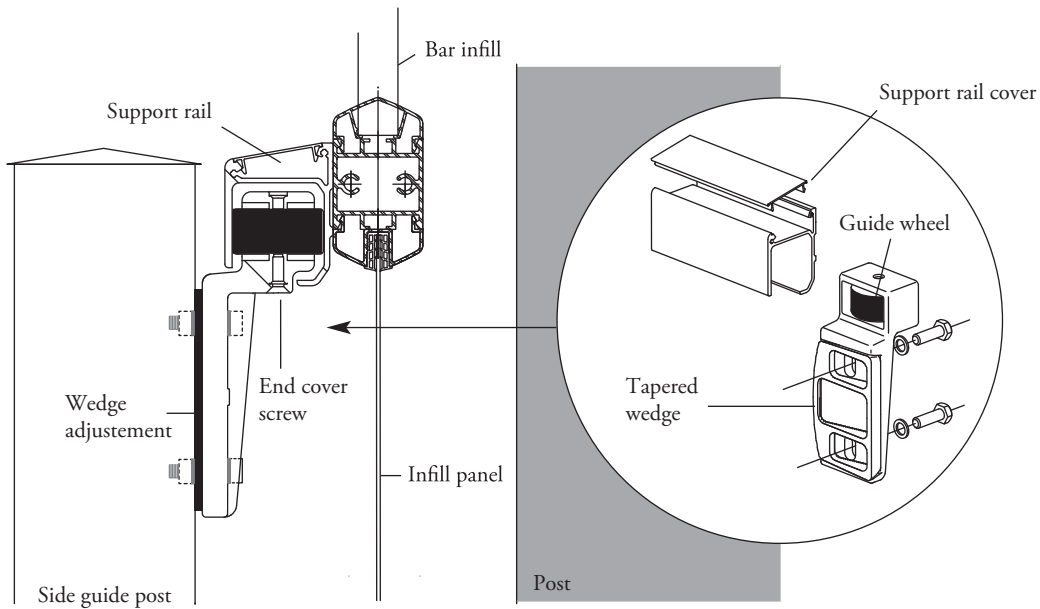
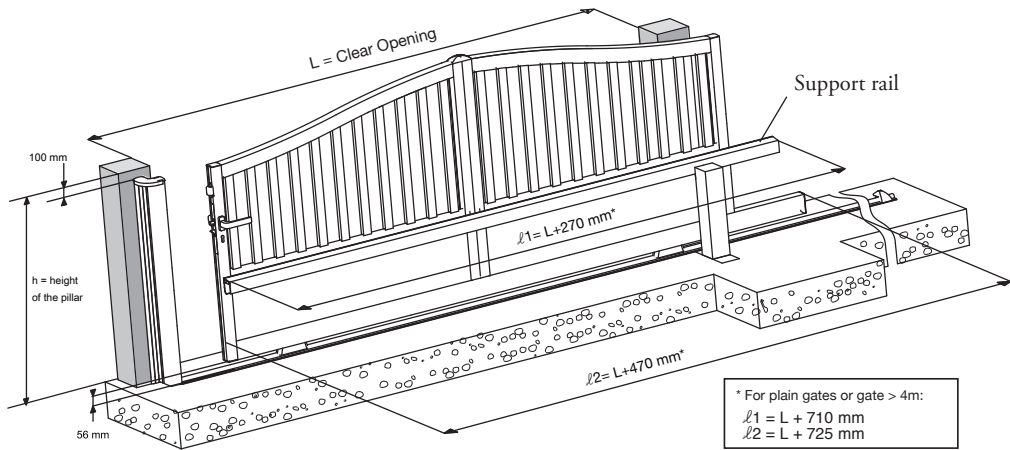

Note the dimension between the gate and the post

K *Fixing the sliding gate end stop*

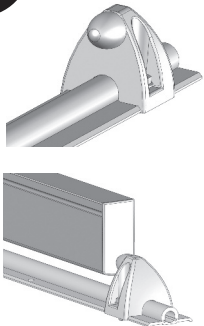

- Move the gate to the rear end position.
- Set the stop against the back of the profile.
- Drill through the rail into the concrete by using the stop as a template, fix the gate stop into the concrete.

L *Final fixing of the catcher post*

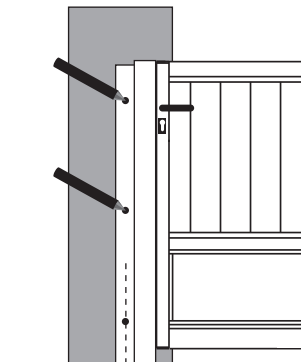

- Slide the gate to the closed position into the catcher post. Adjust the post so that it is well supported against the closing edge of the gate leaf.
- Keep the catcher post in this position and mark the other 2 mounting holes.
- Remove the bottom fixing and drill the 2 new fixing holes.
- Reassemble the catcher post and bolt into place.

M *Setting the catcher for manual gates*

Adjust the height of the catcher post relative to the lock bolt.



N₁ *Fixing the cover to the top of the catcher post for manual gate*

Insert the cover into the profile of the catcher post and tighten the screw with the Allen key 6mm.



N₂ *Fixing the cover to the top of the catcher post for automated gate*

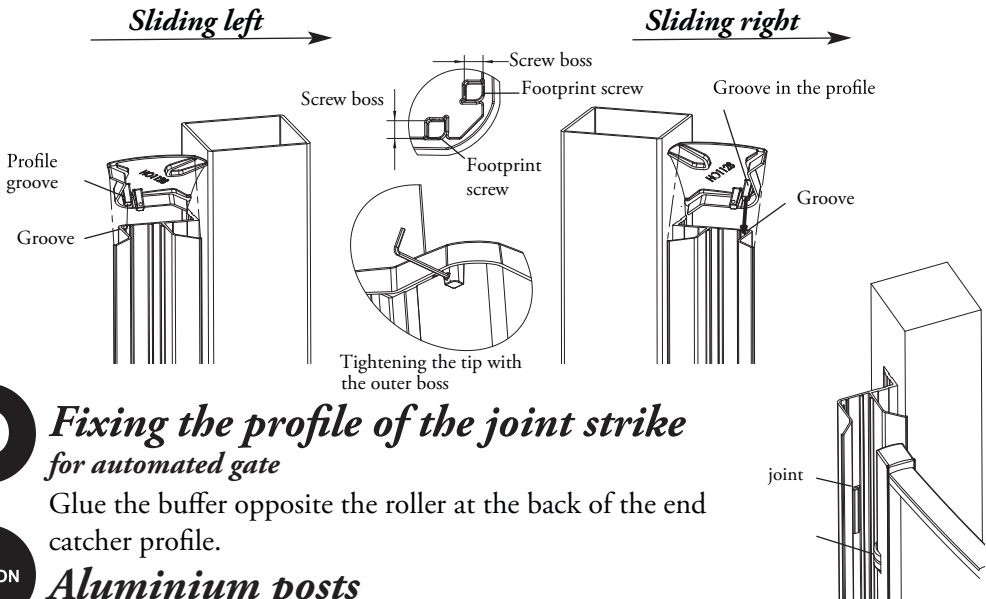

O *Fixing the profile of the joint strike for automated gate*

Glue the buffer opposite the roller at the back of the end catcher profile.

OPTION *Aluminium posts*

If the gate is equipped with posts made of aluminum, 150 x 150 mm, they are adapted to its height. Here is the procedure for their installation.

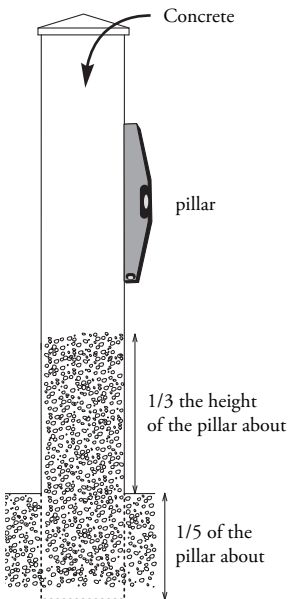

- When setting out dig 2 holes of 200 x 200 mm and a depth of about 1/5 of the total length of the post.

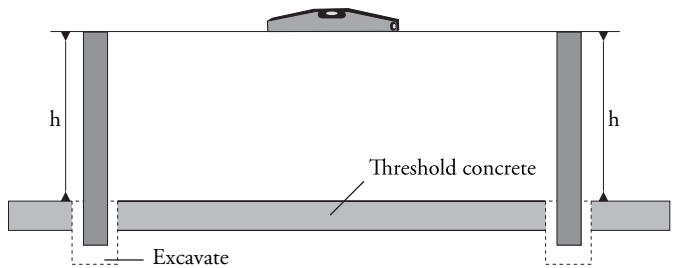

- Insert the pillars in the holes and set them by ensuring they are vertical, to control the level. They must be at the same height. Check the width between the pillars (see step 3).
- The concrete is poured into the hole and then inside of the post. Fill post to 1/3 of it's height.
- Fit the caps.

For the height h, see page 9 or 11

OPTION

Automation

The sliding gates can be automated upon installation or possibly later.

- The automation foundation must be provided, as well as the placement of the ducts for the power, safety devices and access control. Follow precisely one of the diagrams below depending on whether the gate has a top guide or side guide post (or two).

With top guide
FLAT TOP GATES

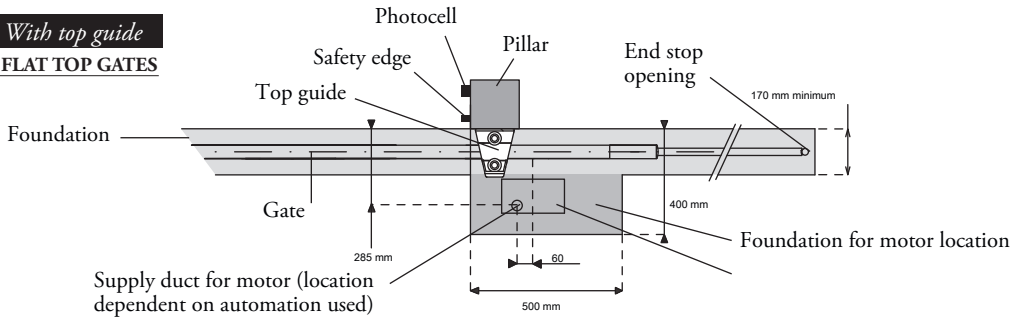

With 1 or 2 side guides
GATES WITH CURVED SHAPE AND TRADITIONAL

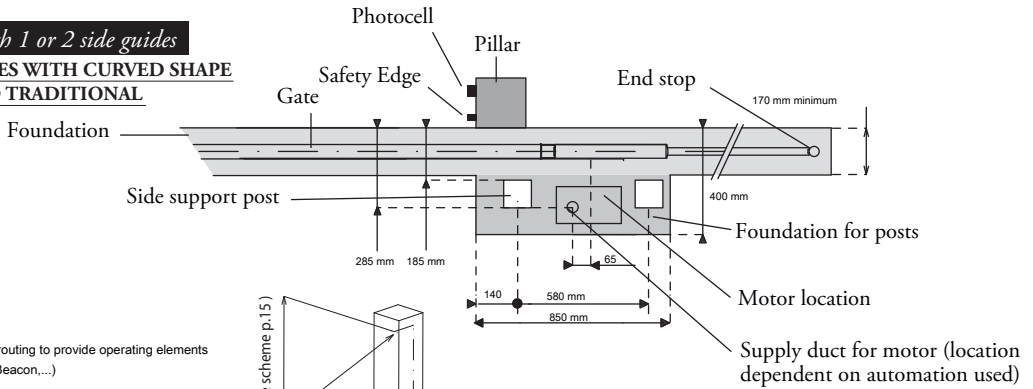

Cable routing to provide operating elements (Pad, Beacon,...)

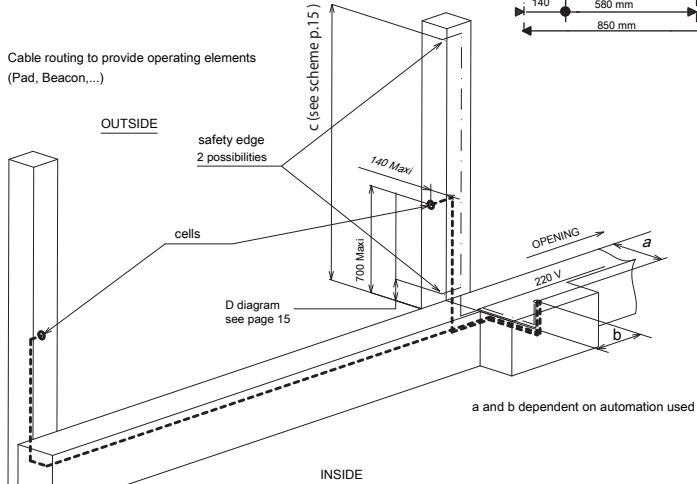

OPTION

Automation (after)

- Motor installation: All configurations for the implementation of the motor are contained in the installation instructions supplied with the motor

- Photocells (see individuals instructions)

Photocell positioning: on the gate post
 Maximum height 700 mm from ground
 Distance from gate leaf maximum 200 mm

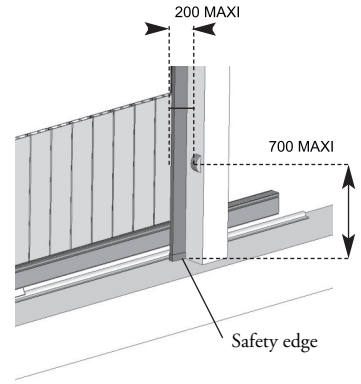

- Installation of the edge:
 This is necessary for automated sliding gates with open bars.
 Here are the different possibilities in the shape and the height of your gate:

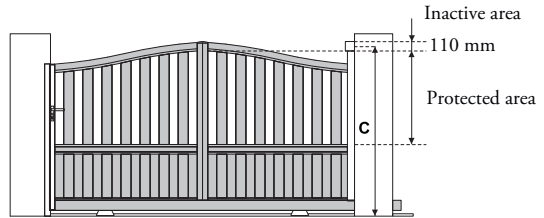

Contemporary range:

Flat top models:

Dimension C = H height of the gate + 50 mm shaped

Models with shape:

Dimension C = H height of the gate at shoulders + 260 mm form

Models with shape:

Dimension C = H height of the gate at shoulders + 50 mm

Exhibit C is given for a maximum width of gate

Dimension D:

Case 1:

For gates which requires a safety edge <2.00 m (safety edge is to intersect): D = at ground level

Case 2:

The safety edge is raised from the ground: dimension D = dimension C - 2000 mm

Traditional range:

Models without finials:

Dimension C = H height of the gate + 85 mm

Models with finials and shape:

Dimension C = H height of the gate at shoulders + 265 mm form

Models with finials and shape:

Dimension C = H height of the gate at shoulders + 505 mm form

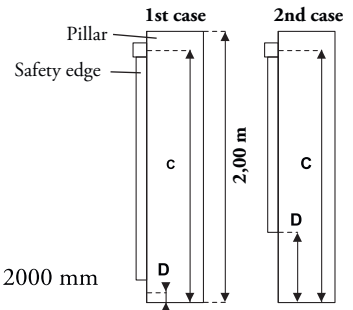

Instructions

Instructions end of construction

Remove the packing materials according to current standards.
All requirements of EN 12604 and EN 12453 must be met and verified if necessary.

Disassembly / Demolition

Any dismantling operation can be undertaken by a professional. The dismantling will be made following the reverse order of assembly. Precautions will be taken to stall the gate to prevent it from falling. The disposal of materials must be made in compliance with standards.

Changes or improvements

Changes or improvements to the portal are allowed only if the portal continues to meet all the requirements of the EN 13241+A2 and UKCA standards.